

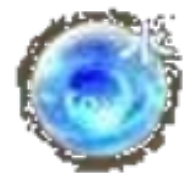

THE SYMBOLIC ELEMENT

Your group's symbolic element is **WATER**, which represents **fluidity, balance, and purification**. In the context of the **United Nations Sustainable Development Goals (UN SDGs)**, water can symbolise technological advancements and innovations aimed at addressing human health, clean water and well-being challenges.



This worksheet addresses the following UN SDGs within the Healthcare industry:

- **Goals 3** Ensure healthy lives and promote well-being for all at all ages.
- **Goals 6** Ensure availability and sustainable management of water and sanitation for all.
- **Goals 15** Protect, restore and promote sustainable use of terrestrial ecosystems, sustainably manage forests, combat desertification, and halt and reverse land degradation and halt biodiversity loss.
- **Goals 17** Revitalize the global partnership for sustainable development.



THE HEALTHCARE INDUSTRY

In the healthcare industry, technologies such as Artificial Intelligence (AI), Robotics, Internet of Things (IoT) can be used to provide efficiency, communication, and sustainability in the healthcare sector.

AI	Robotics	Internet of Things

EXTENDED READING:

Artificial Intelligence (AI): AI aids in medical diagnosis through image analysis. Example: IBM's Health analyses medical images to detect anomalies like cancer.

Robotics: Robotics assists in surgery for precision and minimally invasive procedures. Example: Da Vinci surgical System performs complex surgeries with enhanced precision.

Internet of Things (IoT): IoT monitors patient health remotely. Example: wearable devices like Fitbit track vital signs and send alerts to healthcare providers.



STAGE ONE: USING AI TO CREATE A PEDOMETER

We will use a simple form of AI called a finite state machine (FSM) to program an accurate pedometer within a wearable health and well-being device. For that, we will need:

1. A BBC micro:bit: A pocket-sized computer (see the picture below for more details).

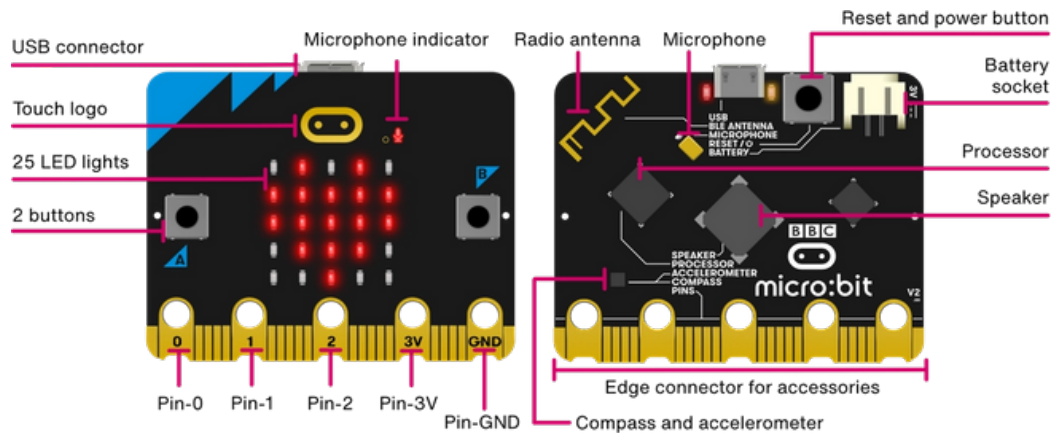







2. A Wear:bit: A Wearable device compatible with the BBC micro:bit. It can be easily made with a simple installing method.

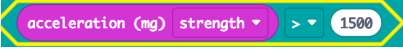

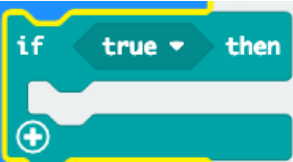

- Below we have some coding building blocks for which, if you put them together in the right order, you can construct a finite state machine (a simple AI system) that uses the BBC micro:bit's accelerometer sensor input to sense when we are moving/walking.
- An accelerometer is a motion sensor that measures movement. (It measures forces in 3 dimensions, including gravity). The accelerometer in the BBC micro:bit detects when you tilt it to the left, right, backwards, or forwards, as well as move it up and down.

What do you think each block of the code listed below does?	Using the code blocks in the left side of this table, write down in this column the correct order of the blocks to count steps while walking.
(1) 	Solution
(2) 	
(3) 	
(4) 	
(5) 	
(6) 	
(7) 	
(8) 	



5. Let's program the Wear:bit with the code you wrote down as your solution for the previous task. To do that, please follow these four steps:

Step 1: Go to <https://makecode.microbit.org/S13235-97312-51255-60661> .

Step 2: Click on the Edit button.



Step 3: That will open a new window. In this window, order the blocks on the screen according to your solution for the previous task.

Step 4: Once done, download your project and copy/install it into the BBC micro:bit attached to the Wear:bit.



Question: Turn the Wear:bit on (see the picture). One person has to wear the Wear:bit and start moving (walking) in the room for 15 sec. What does the Wear:bit do?

Please write down the number you see displayed on the Wear:bit.

Answer (please turn the Wear:bit off after writing the answer):

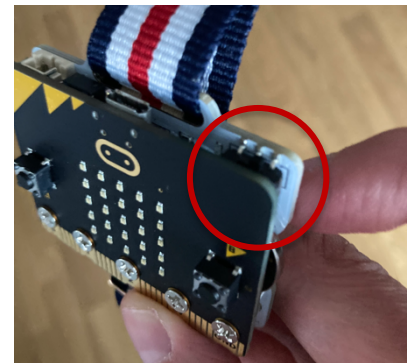



THE MISSION: USING AI TO CREATE A PERSONALISED CALORIE ESTIMATOR WITHIN A WEARABLE DEVICE

An average person will burn about **40 calories per 1,000 steps**. This is the equivalent of **0.04 calories per step**, however, there are other factors which we will discuss below.

You can use this link (<https://www.verywellfit.com/walking-calories-and-distance-calculators-3432711>) to answer the following questions.

Question: How many calories does a female (weight 140 pounds) burn after walking (at moderate speed) for 1 minute?

Please write down your answer below:

Answer:

Question: How many calories does a female (weight 200 pounds) burn after walking (at moderate speed) for 1 minute?

Please write down your answer below:

Answer:

Question: How many calories does a female (weight 140 pounds) burn after walking (brisk) after walk for 1 minute?

Please write down your answer below:

Answer:

Question: How many calories does a female (weight 200 pounds) burn after walking (brisk) after walk for 1 minute?

Please write down your answer below:

Answer:

Question: What do you think are the various factors that play a role in calorie estimation?

Please write down your answer below:

Answer:



STAGE ONE: CREATE A PERSONALISED PEDOMETER

We will use a simple form of AI called a Finite State Machine (FSM) to program a wearable device. It will take as input a person's weight and will detect movement when the person moves. It will attempt to estimate when a calorie is burned:

1. A BBC micro:bit: A pocket-sized computer.
2. A Wear:bit: A wrist-wearable device.
3. In our code, we need to initialise the factors that affect the calorie estimator, which we call (in a computer program) *variables*. The variables in this case are the person's weight, the state (which can be *idle* or *walking*), steps, calories, and the calories per step. At the beginning of the program, we will initialise *state = 0* meaning *idle*, *steps = 0*, *calories = 0*, and *weight = 70*. If the person's weight is <75 Kg, then *calories per step = 0.04*. If the person's weight is >75 Kg, then *calories per step = 0.05*.

```
on start
  set State to 0
  set Steps to 0
  set Calories to 0
  set Weight to 70
  if Weight ≤ 75 then
    set CaloriesPerStep to 0.04
  else
    set CaloriesPerStep to 0.05
```

4. Below we have the coding building blocks, where the code uses *functions*. Functions are "self-contained" pieces of code that accomplish a specific task. Read the code below and the answer the question.

<pre>function DetectStep if acceleration (mg) strength > 1500 then return true else return false</pre>	<p>What does the code shown on the left side do?</p> <p>Solution</p>
---	--



5. STAGE TWO: CONVERT STEPS TO CALORIE BURNED

Let's program the Wear:bit to compute calories burnt. To do that, please follow the steps below:

Step 1: Go to <https://makecode.microbit.org/S04690-86899-06099-35998>

Step 2: Click on the Edit button

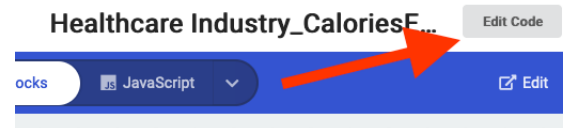

Step 3: Next, you will see a *forever* loop. We are checking the state, and determine whether it's idle or walking, if it's idle then the *state* = 0 and if the *state* = 1, which means the person is walking. However, this code missing two important elements.

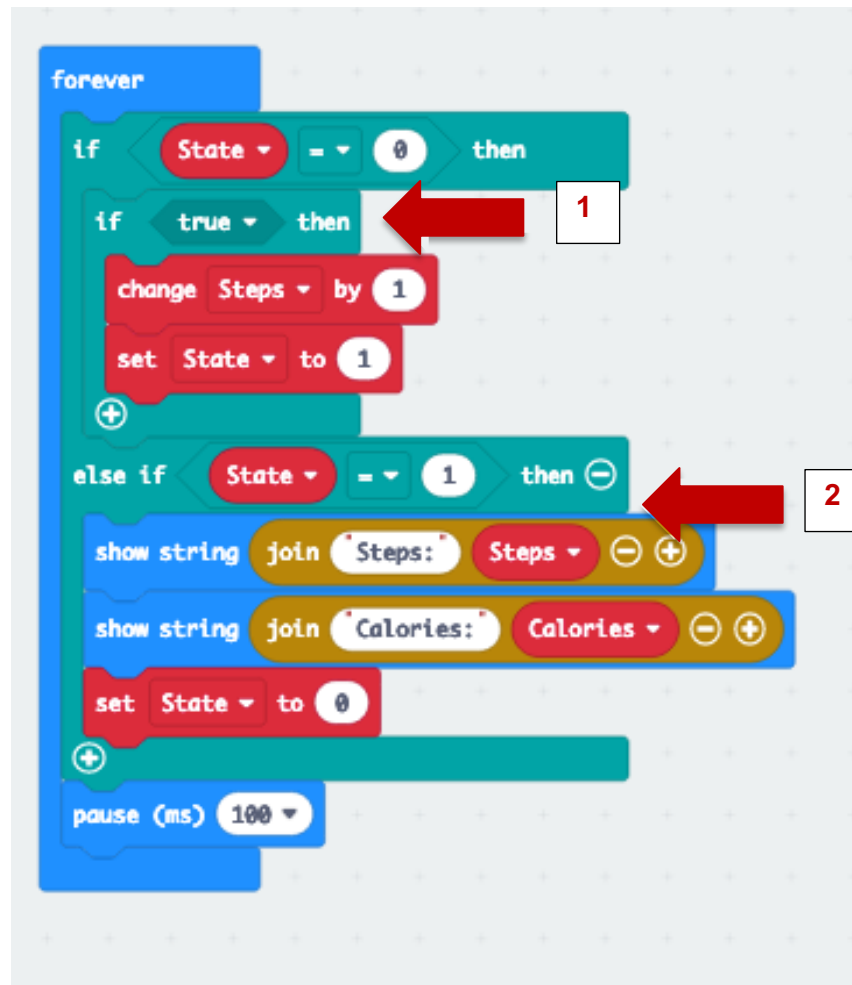



Step 4: For the first element, we need check if the person is walking by checking that the acceleration strength exceeds 1500. That can be done by calling the function “**DetectStep**” inside the *if* statement within the *forever* loop as follows: From the Functions menu, drag and drop the “call **DetectStep**” block inside the *forever* loop at the location shown in the picture below.

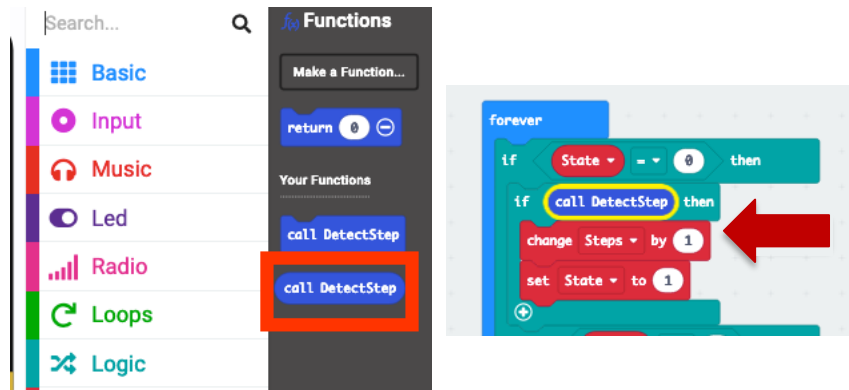

Step 5: After that, we need to drag and drop from the **Variables** menu the block **set Calories to 0**, and place it after the **if statement State = 1**.

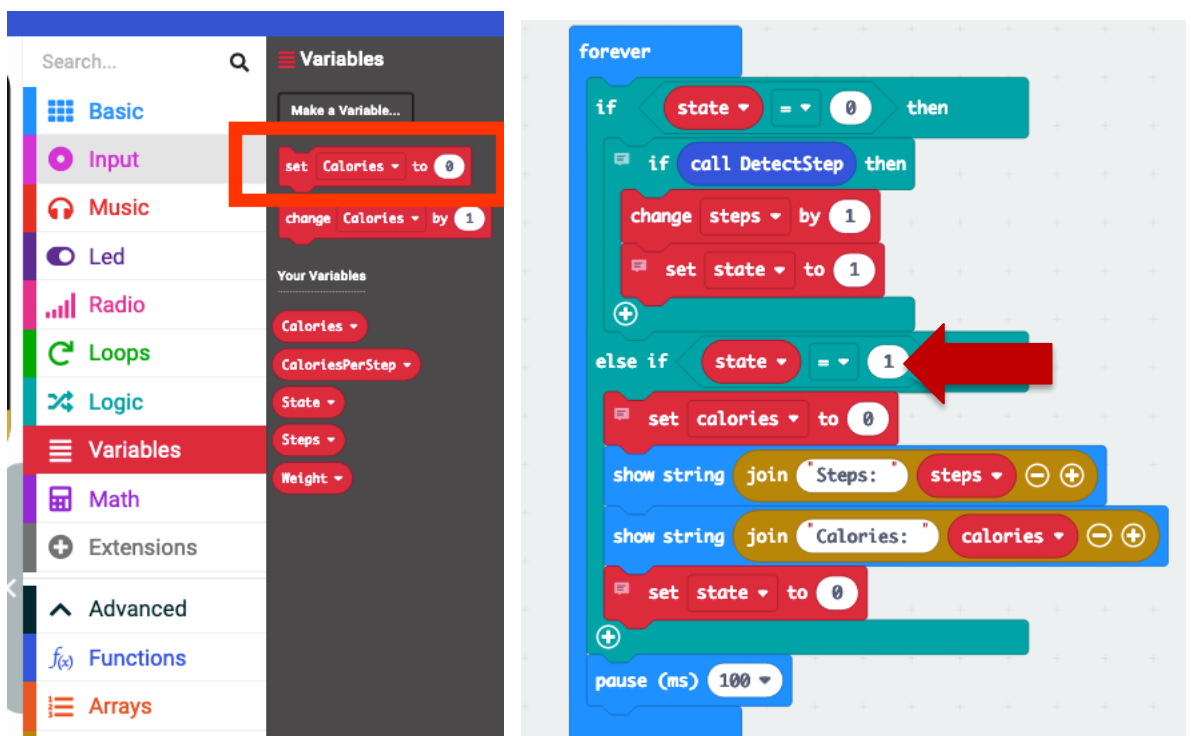



Step 6: After that, we need to calculate how many calories have been burnt after a step has occurred. This can be done by multiplying the steps with the calories per step. You can do that by dragging and dropping from the **Math** menu the **multiplication operator** to inside the 0 within the **set Calories to 0** block.

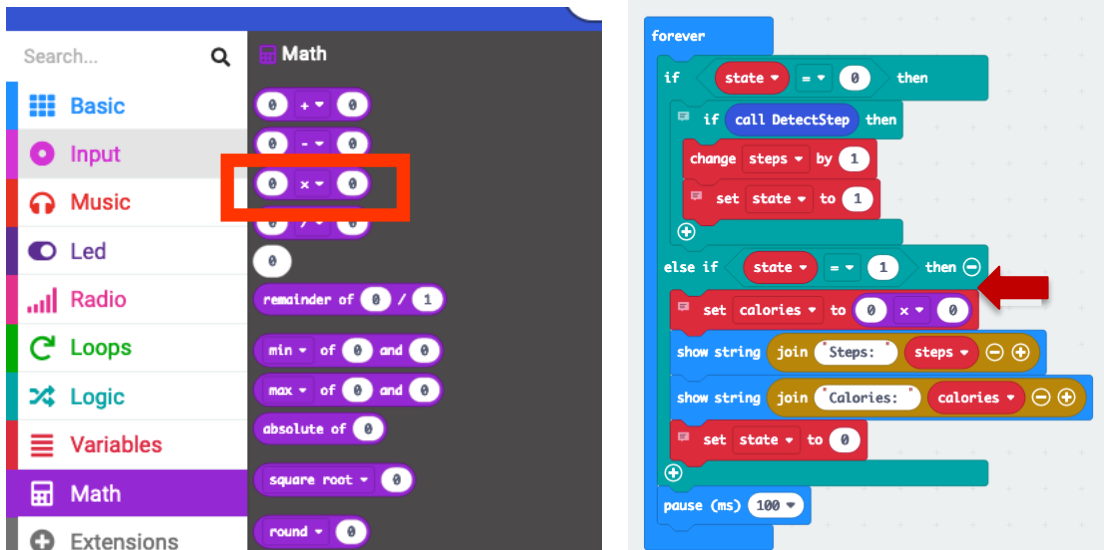

Step 7: Now inside the left 0 position, drag and drop the *steps* from the **Variables**. in the right 0 position, drag and drop *CaloriesPerStep* (see the screenshot below).

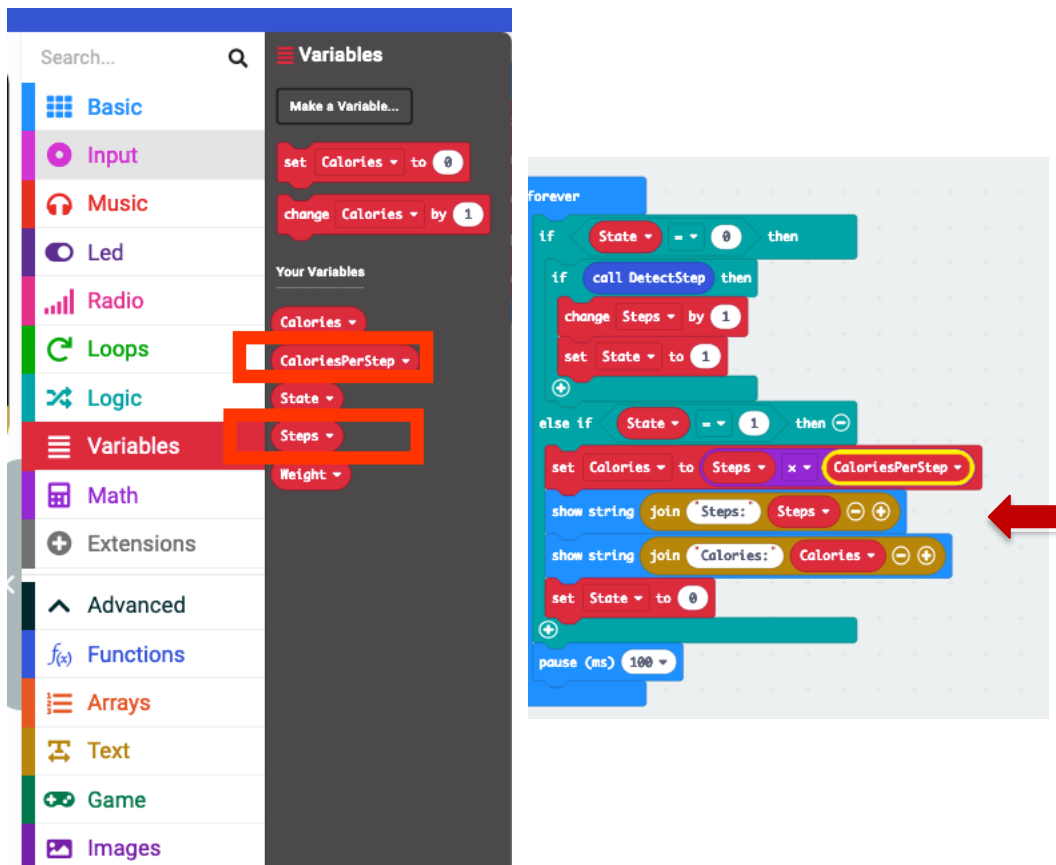



Step 8: Download your project and copy/install it into the BBC micro:bit attached to the Wear:bit.



Question: Turn the Wear:bit on (see the picture). One person has to wear the Wear:bit and start moving (walking) in room for 1 minute. How many steps and calories does the Wear:bit display? Please write down the number you see displayed on the Wear:bit.

Answer (please turn the Wear:bit off after writing the answer):

