

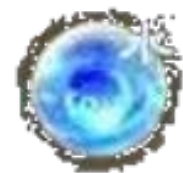

THE SYMBOLIC ELEMENT

Your group's symbolic element is **WATER**, which represents **fluidity, balance, and purification**. In the context of the **United Nations Sustainable Development Goals (UN SDGs)**, water can symbolise technological advancements and innovations aimed at addressing human health, clean water and well-being challenges.



This worksheet addresses the following UN SDGs within the Healthcare industry:

- **Goals 3** Ensure healthy lives and promote well-being for all at all ages.
- **Goals 6** Ensure availability and sustainable management of water and sanitation for all.
- **Goals 15** Protect, restore and promote sustainable use of terrestrial ecosystems, sustainably manage forests, combat desertification, and halt and reverse land degradation and halt biodiversity loss.
- **Goals 17** Revitalize the global partnership for sustainable development.



THE HEALTHCARE INDUSTRY

In the healthcare industry, technologies such as Artificial Intelligence (AI), Robotics, Internet of Things (IoT) can be used to provide efficiency, communication, and sustainability in the healthcare sector.

AI	Robotics	Internet of Things

EXTENDED READING:

Artificial Intelligence (AI): AI aids in medical diagnosis through image analysis. Example: IBM's Health analyses medical images to detect anomalies like cancer.

Robotics: Robotics assists in surgery for precision and minimally invasive procedures. Example: Da Vinci surgical System performs complex surgeries with enhanced precision.

Internet of Things (IoT): IoT monitors patient health remotely. Example: wearable devices like Fitbit track vital signs and send alerts to healthcare providers.



THE “INTERNET OF THINGS” (IoT) TECHNOLOGY

- Internet of Things (IoT) is about things that have the ability to connect with other things and form networks via the Internet.
- IoT helps with increasing automation, reducing costs, and improving end-customer experience.
- IoT technology can be used to enforce social distancing, which is a public health measure designed to prevent the spread of contagious diseases, such as COVID-19.
- IoT technology helps to monitor patients allowing nurses and doctors to keep track of an individual's health.



THE MISSION: TO DETECT SIGNALS BETWEEN TWO SMART BADGES

IoT Technology can be used with smart badges in hospitals/workplaces to detect proximity between people. Then, send a beep or display a visual alert when people get closer than they should be. Smart badges can also be used to monitor hospitalised patients.

Question: During COVID-19, what was the World Health Organization’s (WHO’s) recommendation for social distancing (in metres)?

Please write down your answer below.

Answer:

Question: How did enforcing social distancing prevent overwhelming healthcare systems during COVID-19?

Please write down your answer below.

Answer:

Question: How can technology help with social distancing?

Please write down your answer below:

Answer:



STAGE ONE: USING THE IOT TO ENFORCE SOCIAL DISTANCING

We use the following pieces of equipment:

1. Two BBC micro:bits: A pocket-sized computer (see the picture below for more details). We will use the radio functionality inside the BBC micro:bits.

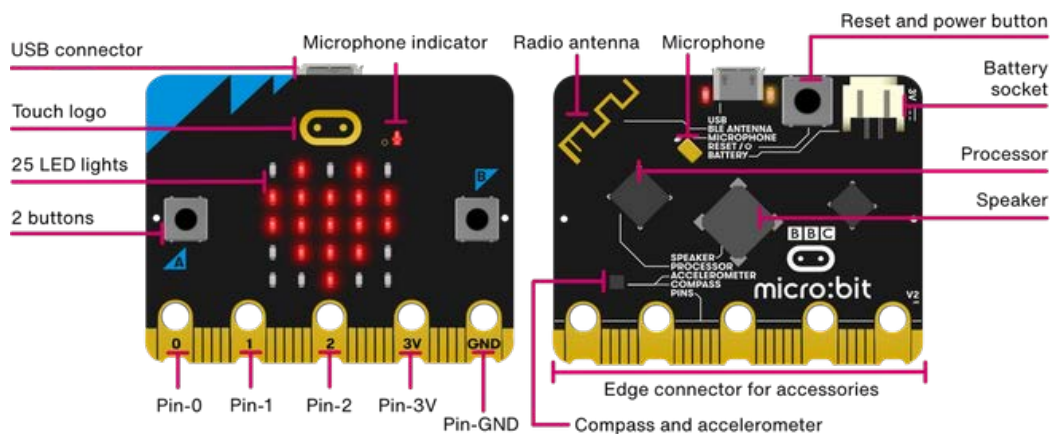

2. Two Egg:Bits: two lightweight, wearable devices with emotive face, 4 buttons, and an ultrasonic distance sensor. The Egg:Bit is a wearable device based on the BBC micro:bit. We will use the ultrasonic distance inside the Egg:Bit.

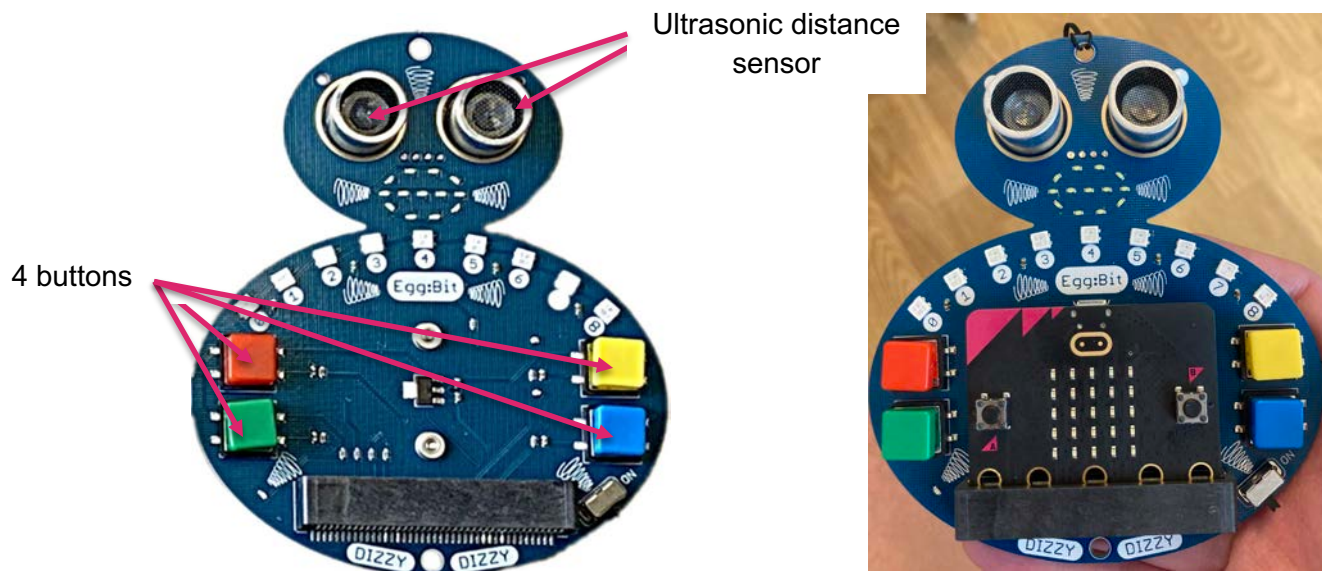



- We will use the radio functionality inside the BBC micro:bits attached to the Egg:Bits. Radio transmission is a way of sending and receiving messages: BBC micro:bits attached to the Egg:Bits can use radio waves to communicate with each other.

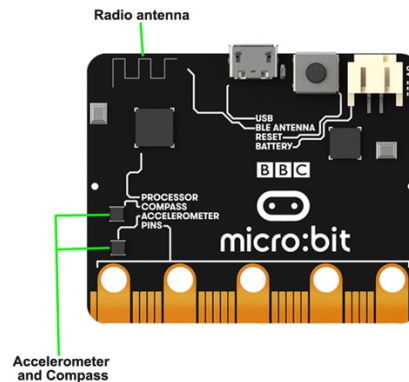

- We will use the ultrasonic sensor in Egg:Bits to detect if two Egg:bits are getting closer to than 1m to each other. Then, a visual alert on the Egg:bits is triggered.
- Let's program the BBC micro:bits and Egg:Bits to detect distance between two Egg:bits when they are facing each other. To do that, please follow the steps below:

Step 1: Go to <https://makecode.microbit.org/S70839-57743-78596-80622> .

Step 2: Click on the Edit button.



Step 3: You will notice that there is 1) an **on start** block 2) a **forever** block, as shown in the screenshot below. Inside the **on start**, the radio group is initialised using a **radio set group** command, which is set to 70. This will allow both Egg:Bits to communicate with each other through this radio group. Inside the **on start**, there is a variable called **DistanceThreshold** and it is set to 100 cm (1 metre), which means that if the Egg:Bits get closer than 1 metre to each other, a visual alert will be triggered.

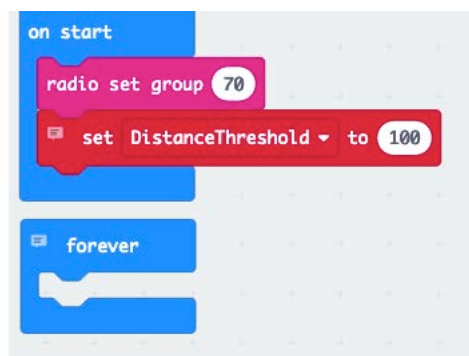



Step 4: Now, we need to read the ultrasonic sensor in the Egg:bits in centimetre and to check if the two Egg:Bits are close than the **DistanceThreshold**, which is set to 100 cm. You need to drag and drop an if statement and comparison statement from the Logic menu inside the **forever** block as shown in screenshot below.

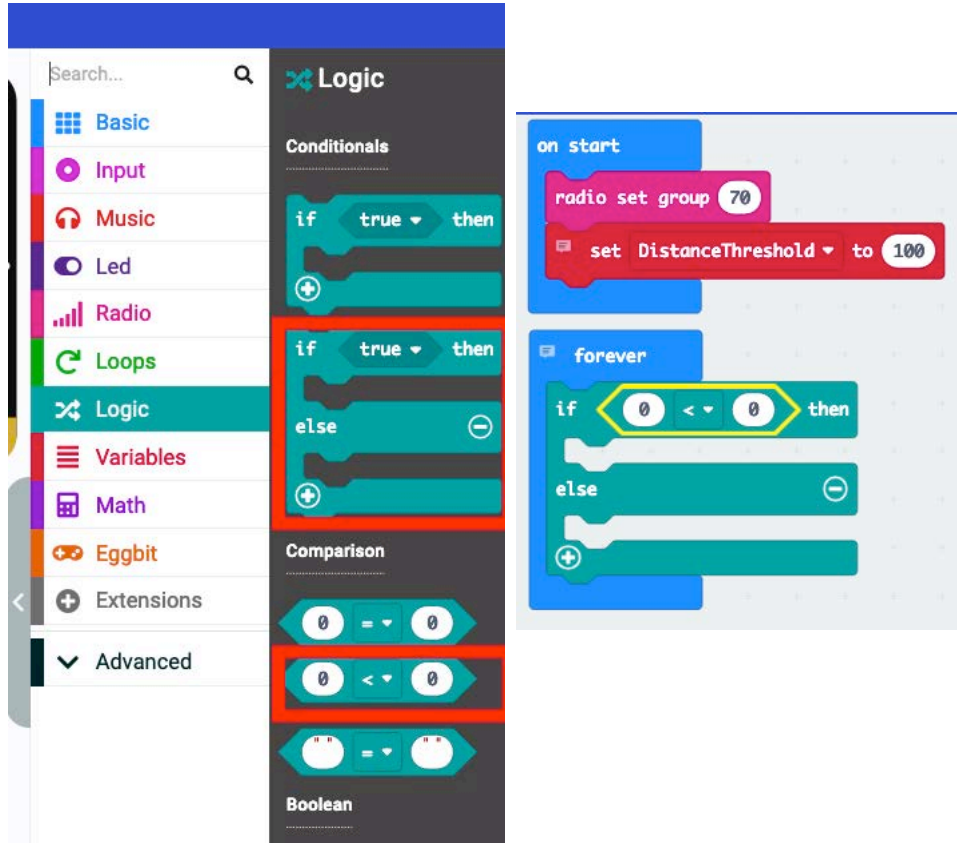

Step 5: In places of the zeros, drag and drop from the **Eggbit (Input/Output)** menu, the **read sonar as cm** block in the place of the zero in the left side of comparison. From the **Variable** menu, drag and drop the **DistanceThreshold**, and place it in right side of comparison.

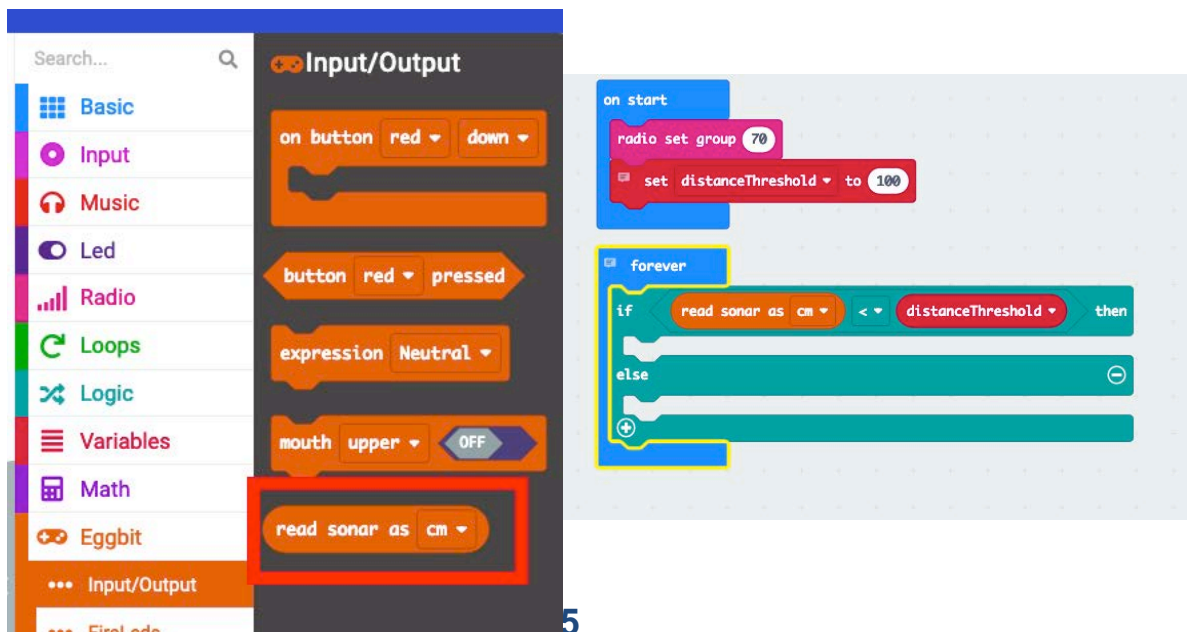



Step 6: Now, inside the **if** statement, if the reading of the ultrasonic sensor in cm is less than the distance threshold (100 cm). Then you need to send message through the radio to the other Egg:Bit that the distance now is too close. This can be done by drag and drop from the **Radio** the **radio send string** and type “close” string. Then from the **Basic** menu, select **pause (ms)** 100.

```
on start
  radio set group 70
  set distanceThreshold to 100

forever
  if read sonar as cm < distanceThreshold then
    radio send string 'close'
    pause (ms) 100
  else
    
```

Step 7: Then, inside the **else** statement, you need to send message through the radio to the other Egg:Bit that the distance now is safe. This can be done by drag and drop from the **Radio** the **radio send string** and type the string “safe”. Then from the **Basic** menu, select **pause (ms)** 100.

```
on start
  radio set group 70
  set distanceThreshold to 100

forever
  if read sonar as cm < distanceThreshold then
    radio send string 'close'
    pause (ms) 100
  else
    radio send string 'safe'
    pause (ms) 100
  
```



Step 8: After that, we need to receive those messages sent by the BBC micro:bits attached to the Egg:Bits, and set a visual alert (red when the two Egg:Bits are too close and green when the distance is safe). This can be done by dragging and dropping **on radio received** from the **Radio** menu. See the screenshot below.

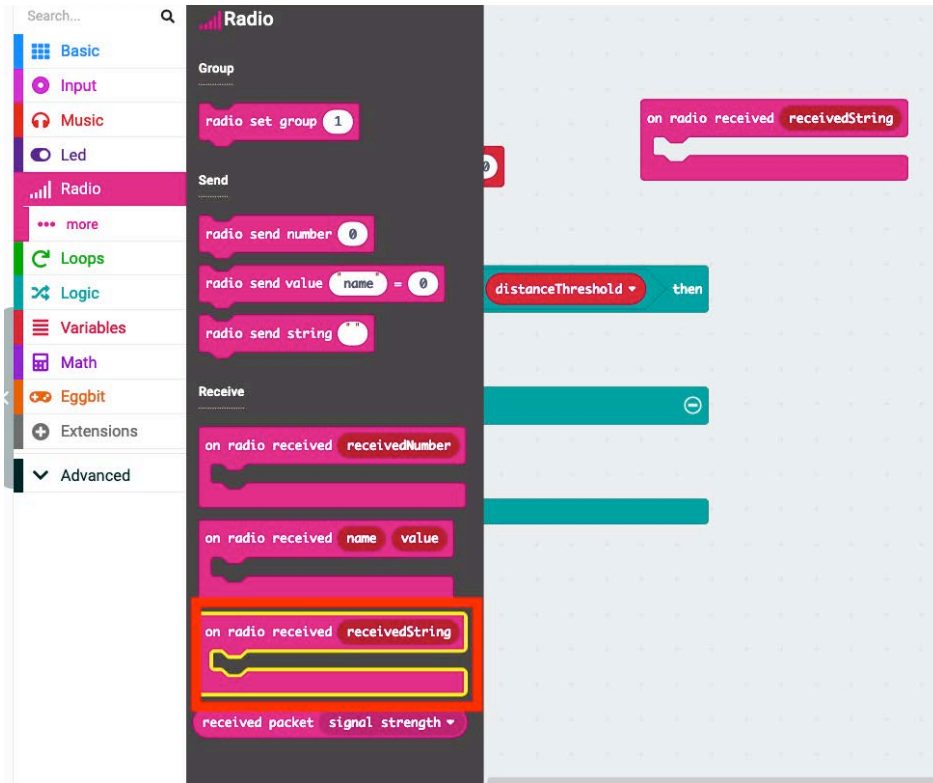

Step 9: Then, you need to drag and drop an *if* statement and comparison statement from the Logic menu to inside the **on radio received** block, as shown in screenshot below.

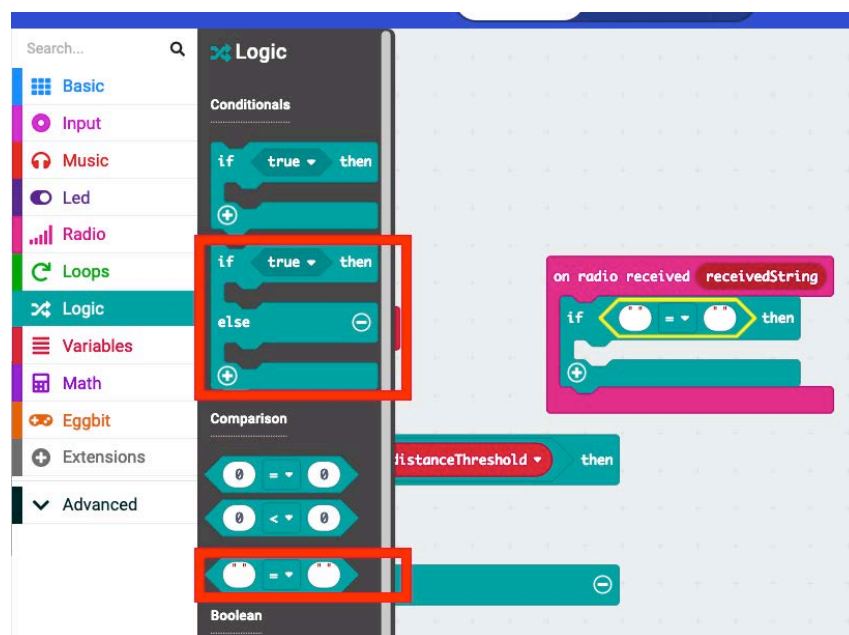



Step 10: Drag and drop **receivedString** into the *if* statement of the **on radio received** block, in place of the “ ” on the left side of the comparison. Type “close” in the space of the right side “ ” of the comparison.

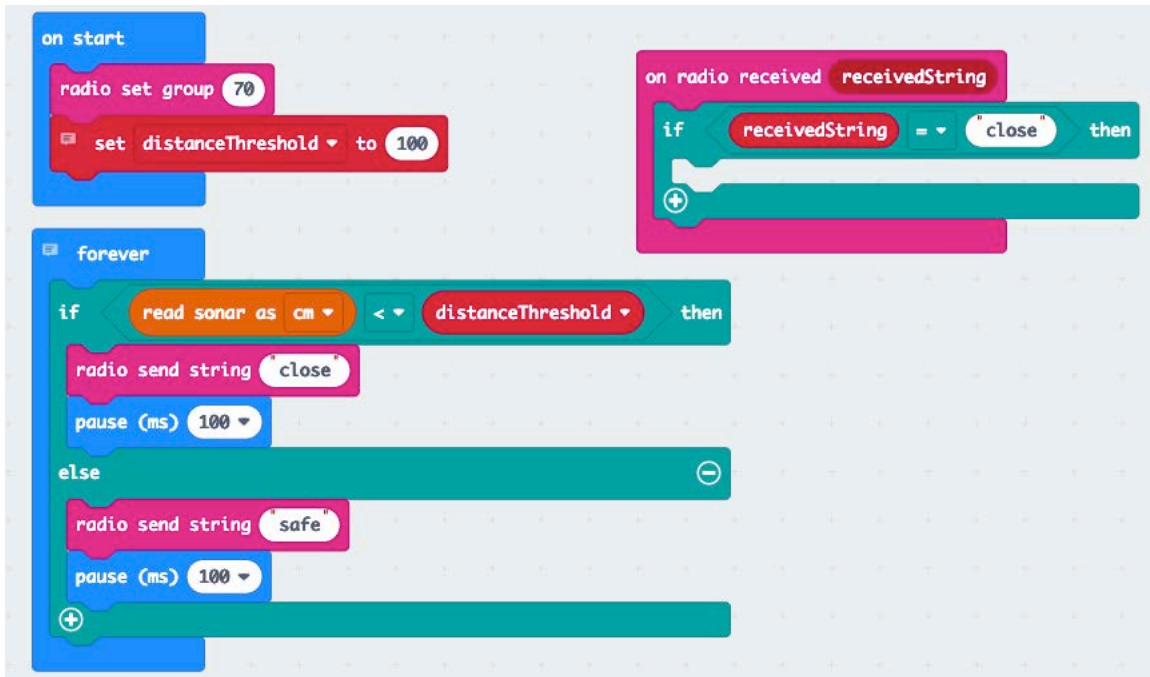

Step 11: Inside the *if* statement, drag and drop from the **Eggbit menu** from the **FireLeds**, the **set all FireLEDs to Red** block. See the screenshot below.

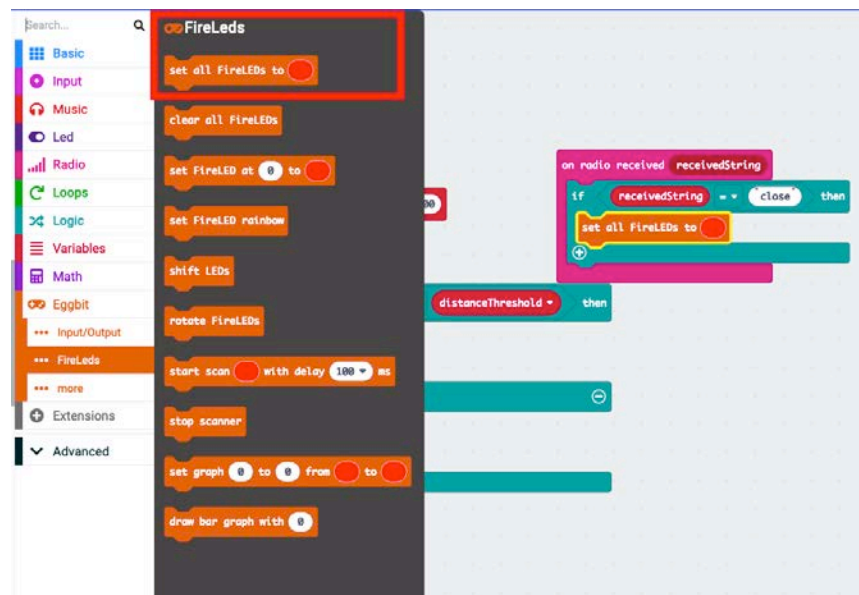



Step 12: Inside the **else** statement, drag and drop from the **if** statement from the **Logic** menu, and add a comparison statement. In the places of the spaces, drag and drop **receivedString** on the left “**=**”, and type “**safe**” in the right “**=**”.

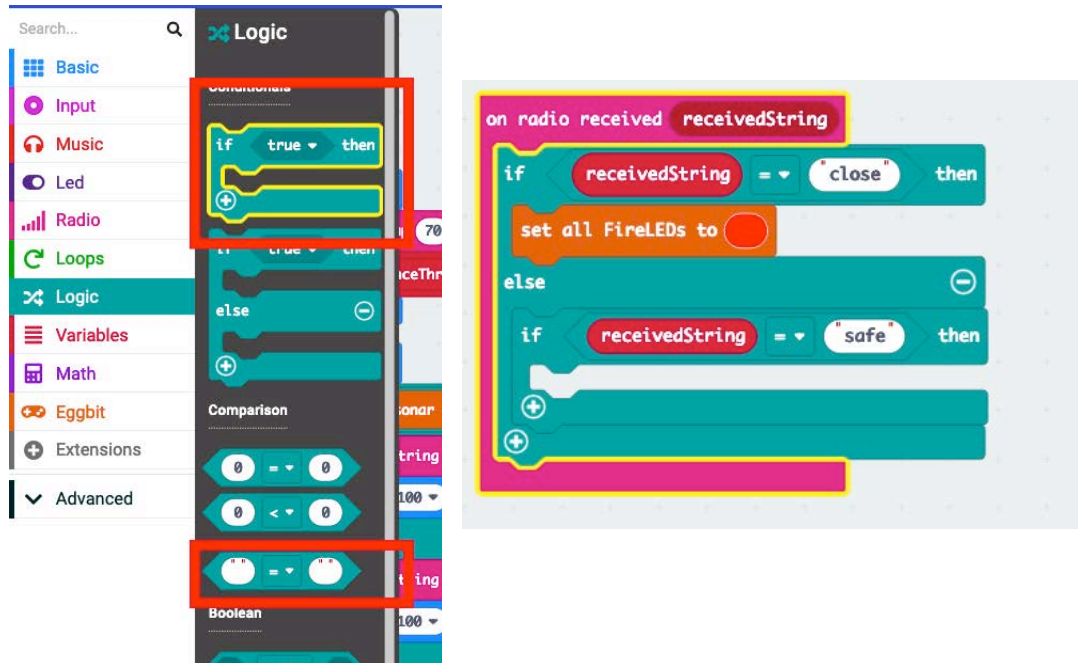

Step 13: Inside the **if** statement, drag and drop from the **Eggbit** menu from the **FireLEDs**, the **set all FireLEDs to Green** block. See the screenshot below.

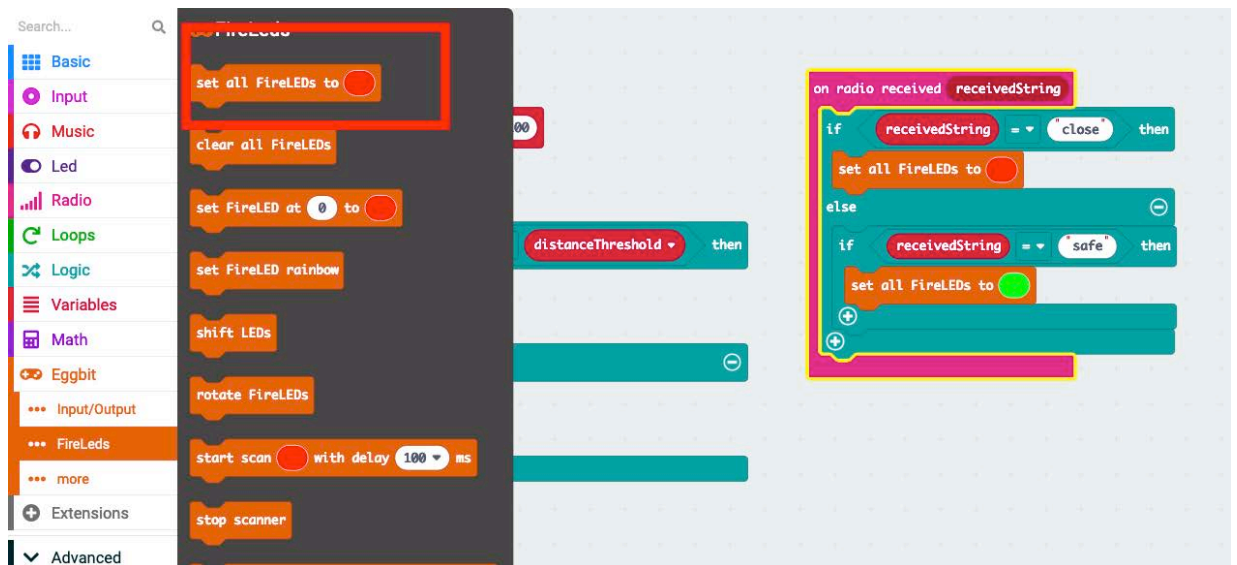



Step 14: The final code will look like the screenshot below

```
on start
  radio set group 70
  set distanceThreshold to 100

forever
  if read sonar as cm < distanceThreshold then
    radio send string 'close'
    pause (ms) 100
  else
    radio send string 'safe'
    pause (ms) 100

on radio received receivedString
  if receivedString == 'close' then
    set all FireLEDs to red
  else
    if receivedString == 'safe' then
      set all FireLEDs to green
```

Step 15: Download your project and copy/install it into the BBC micro:bits.



Step 16: Attach each BBC micro:bit to the Egg:bits similar to picture below.

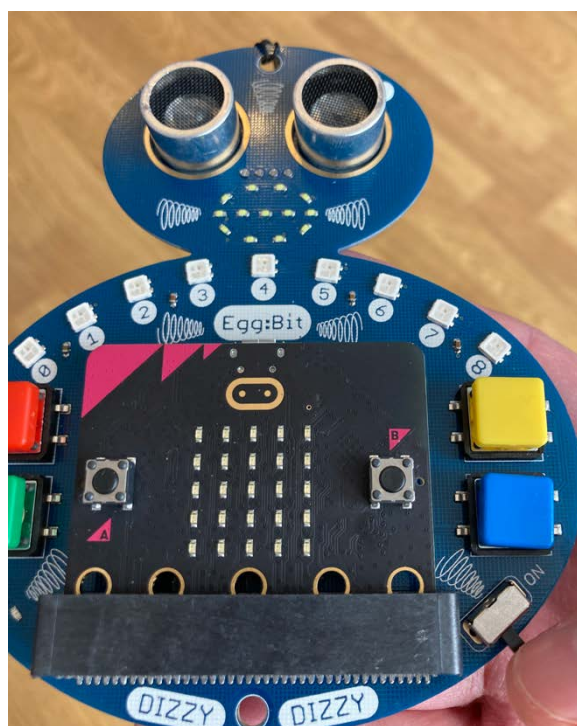



Step 17: One of you has to wear the blue Egg:bit and another one has to wear the yellow Egg:bit.

Question: Turn on the power button on the Egg:bit (see the picture). Then, stand and face each other at a close distance and at a far distance. What do you notice?

Please write down your answer below
(please turn off the power button after you write your answer).

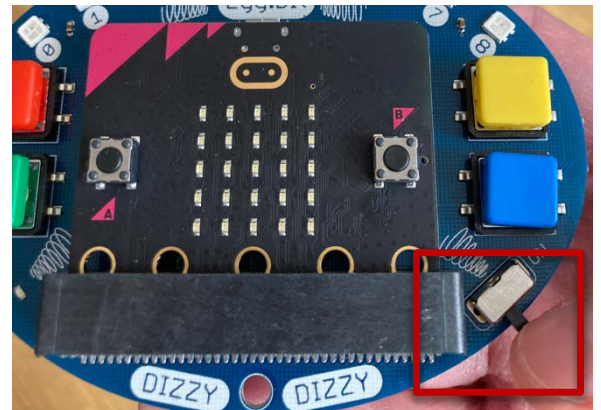



THE MISSION: USE IOT TO SEND AN EMERGENCY SIGNAL FROM A PATIENT TO A NURSE IN A HOSPITAL SETTING

1. To do that, we will use the same equipment from the previous task: 1) Two BBC micro:bits
2) Two Egg:Bits.
2. We will only use the radio functionality inside the BBC micro:bits attached to the Egg:Bits. Radio transmission is a way of sending and receiving messages: BBC micro:bits attached to the Egg:Bits can use radio waves to communicate with each other.
3. Let's program one BBC micro:bit to send a signal and one BBC to receive that signal.
4. We need to program the patient's wearable Egg:bit (**the sender's blue Egg:bit**) through its BBC micro:bit to send a signal when the patient presses the red button.

```
on start
  radio set group 70
  set PatientID to 1

on button red down
  set all FireLEDs to [red]
  radio send string join "Patient No:" PatientID
```

Question: In your opinion, what does the above code do?
Please write down your answer below.

Answer:

5. Now, go to <https://makecode.microbit.org/S09987-78074-92843-13183> .
6. Click the edit button and then download your project and copy/install it into the BBC micro:bit. Attach the BBC micro:bit to the blue Egg:bit.





7. We need to program the nurse's wearable Egg:bit (**the receiver's yellow Egg:bit**) through its BBC micro:bit, to receive a signal, when the patient presses the red button.

Question: In your opinion, what does the above code do?
Please write down your answer below:

Answer:

8. Now, go to <https://makecode.microbit.org/S59568-38885-14091-54414> .
9. Click the edit button and then download your project and copy/install it into the BBC micro:bit. Attach the BBC micro:bit to the yellow Egg:bit.
10. One of you has to wear the blue Egg:bit and another one has to wear the yellow Egg:bit.



Question: Turn on the power button on both Egg:Bits (see the picture). Then, if the one wearing the blue Egg:Bit presses the red button, what do you notice?

Please write down your answer below:

